



Model No. 668-28

**Pressurematic Water
System**

Part No. 8940

Product Code: O/C GJAN23.RBVB-DC35B

**COMPONENT
MAINTENANCE MANUAL
with
ILLUSTRATED PARTS LIST**

PART NO. 5912
REV. D
01/17/05

MICROPUMP, INC.

A Unit of IDEX Corporation

PO Box 8975, Vancouver, WA 98668-8975 • Phone: 360/253-2008 • Fax: 360/253-8294

MICROPUMP LIMITED

A Subsidiary of Micropump, Inc.

Howard Road, Eaton Socon, St. Neots, Cambridgeshire, PE 19 8ET England, • Phone: (44) (0) 1480-356600 • Fax: (44) (0) 1480-356300

INTRODUCTION

This manual provides the information needed for the shop mechanic to determine the condition of the Micropump Model 668-28 Pressurematic Water System and enable him to restore it to serviceable status if necessary.

The manual first describes the system. It then presents detailed procedures in a logical sequence, detailing how to access serviceability, disassembly and clean, check, repair, assemble, and store. An Illustrated Parts List concludes the manual.

All procedures are shop verified; that is, the manufacturer has used the procedures presented herein.

The way to use the manual depends mainly on the immediate objective. For example, to reach a go-no go decision on a system, one need only refer to Testing and Troubleshooting... to make a repair, refer to Repair... and so on. If the objective is a complete overhaul, however, one must make use of the whole manual.

MICROPUMP, INC.

A Unit of IDEX Corporation

PO Box 8975, Vancouver, WA 98668-8975 • Phone: 360/253-2008 • Fax: 360/253-8294

MICROPUMP LIMITED

A Subsidiary of Micropump, Inc.

Howard Road, Eaton Socon, St. Neots, Cambridgeshire, PE 19 8ET England. • Phone: (44) (0) 1480-356600 • Fax: (44) (0) 1480-356300

1. Description and Operation

1.1 General Description

- 1.1.1 The Model 668-28 Pressurematic Water System is a complete electrically powered, constant displacement pump unit. It is used to supply a steady water pressure of approximately 20 psig (1.38 bar) and a maximum flow rate of 1.5 gpm (5.6 l/m) for the water outlets in aircraft equipped with gravity tanks. In aircraft with pressurized water tanks, the Model 668-28 provides boost pressure to approximately 20 psig (1.38 bar) above cabin pressure.
- 1.1.2 Integral parts of the pump unit include a pump pressure regulator, system check valve and flow sensor, over-pressure release valve, and pressure switch. A separate push-button start switch with indicator light is also supplied.
- 1.1.3 The pump unit will withstand pressure surges to 120 psig (8.28 bar) without damage, leaks or malfunction. It employs magnetic coupling between the drive motor and pump assembly and is therefore leak-proof and contamination free.

1.2 Specifications

- 1.2.1 Specifications for the Model 668-28 Pressurematic Water System are as follows:

- 1.2.1.1 Pump Type: Gear, positive displacement
- 1.2.1.2 Motor Type: Direct current, 2350 rpm
- 1.2.1.3 Electrical: 28 V dc, 12 amps maximum, 5 amps continuous
- 1.2.1.4 Ports: AND 10050-6
- 1.2.1.5 Pressure Regulator Adjustment: 20 psig (1.38 bar)
- 1.2.1.6 Flow: 0-1.5 gpm (0-5.6 l/m)
- 1.2.1.7 Weight (Shipping): 4.6 lb (2.08 kg)
- 1.2.1.8 Dimensions: as given in Figure A.

1.3 Operation

- 1.3.1 Drive power for the pump unit is supplied by a self-contained motor assembly that is magnetically coupled to a positive displacement gear pump assembly. Figure B shows a simplified schematic diagram of the pump assembly.
- 1.3.2 Water enters from the supply tank at the inlet port (1), passes through the inlet screen (2), and is pressurized by the impeller gears (3). The pressurized flow can then proceed either to the discharge port through channel A or back to the inlet side of the pump via the bypass channel B and the pressure regulator assembly (4).

MICROPUMP, INC.

A Unit of IDEX Corporation

PO Box 8975, Vancouver, WA 98668-8975 • Phone: 360/253-2008 • Fax: 360/253-8294

MICROPUMP LIMITED

A Subsidiary of Micropump, Inc.

Howard Road, Eaton Socon, St. Neots, Cambridgeshire, PE 19 8ET England. • Phone: (44) (0) 1480-356600 • Fax: (44) (0) 1480-356300

- 1.3.3 Normally, the constant-displacement pump delivers more flow than the water outlets connected to the system require. The excess pump flow is recirculated through the bypass channel and is used by the pressure regulator to set the pump discharge pressure.
- 1.3.4 In the pressure regulator, atmospheric pressure and the spring (5) act together against piston (6), and are opposed by the force of the water pressure acting on the opposite side of the piston. The spring (5) is adjustable externally by means of adjusting screw (7) and locking nut (8), and the space behind the piston is vented to atmosphere through the vent hole (9). Thus, the pump discharge pressure is set with reference to the ambient air pressure by the spring (5), and is relatively insensitive to changes in the water pressure supplied at inlet port (1).
- 1.3.5 Proceeding along channel A to the water outlets, the useful portion of the pump flow first passes check ball (10), which is forced back against opening (11) in sleeve (12) by the flow. To get past sleeve (12) it must compress spring (13), allowing piston (14) to move back. The force of spring (13) causes a pressure drop of approximately 5 psi to occur at this point. As a result, the system pressure beyond this point, including the pressure switch cavity (16), is depressed approximately 5 psi below that set by the pump bypass pressure regulator (4) when there is flow to the water outlets connected to the discharge port (22).

MICROPUMP, INC.

A Unit of IDEX Corporation

PO Box 8975, Vancouver, WA 98668-8975 • Phone: 360/253-2008 • Fax: 360/253-8294

MICROPUMP LIMITED

A Subsidiary of Micropump, Inc.

Howard Road, Eaton Socon, St. Neots, Cambridgeshire, PE 19 8ET England. • Phone: (44) (0) 1480-356600 • Fax: (44) (0) 1480-356300

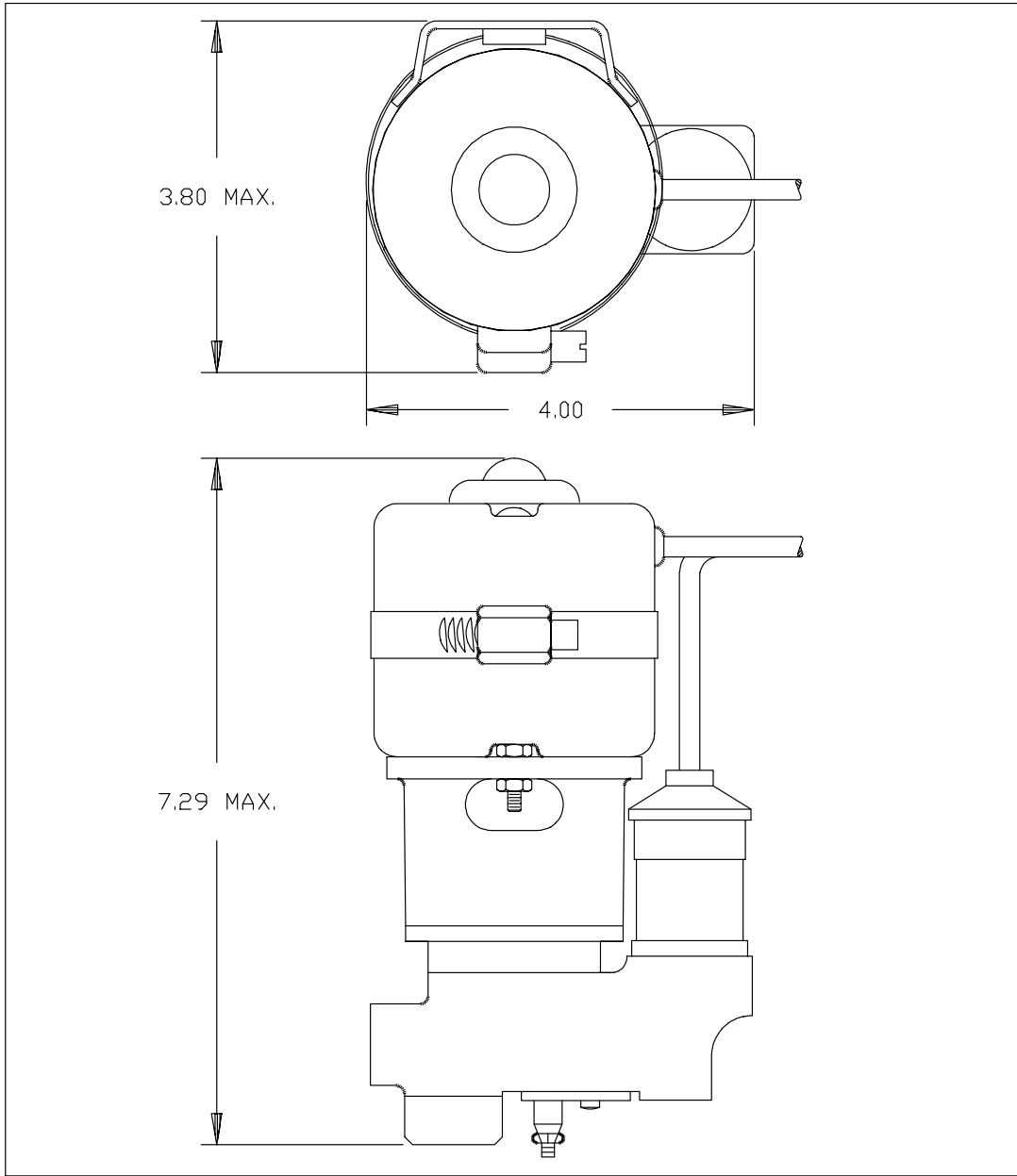

Outline Drawing of Model 668-28
Figure A

MICROPUMP, INC.

A Unit of IDEX Corporation

PO Box 8975, Vancouver, WA 98668-8975 • Phone: 360/253-2008 • Fax: 360/253-8294

MICROPUMP LIMITED

A Subsidiary of Micropump, Inc.

Howard Road, Eaton Socon, St. Neots, Cambridgeshire, PE 19 8ET England. • Phone: (44) (0) 1480-356600 • Fax: (44) (0) 1480-356300

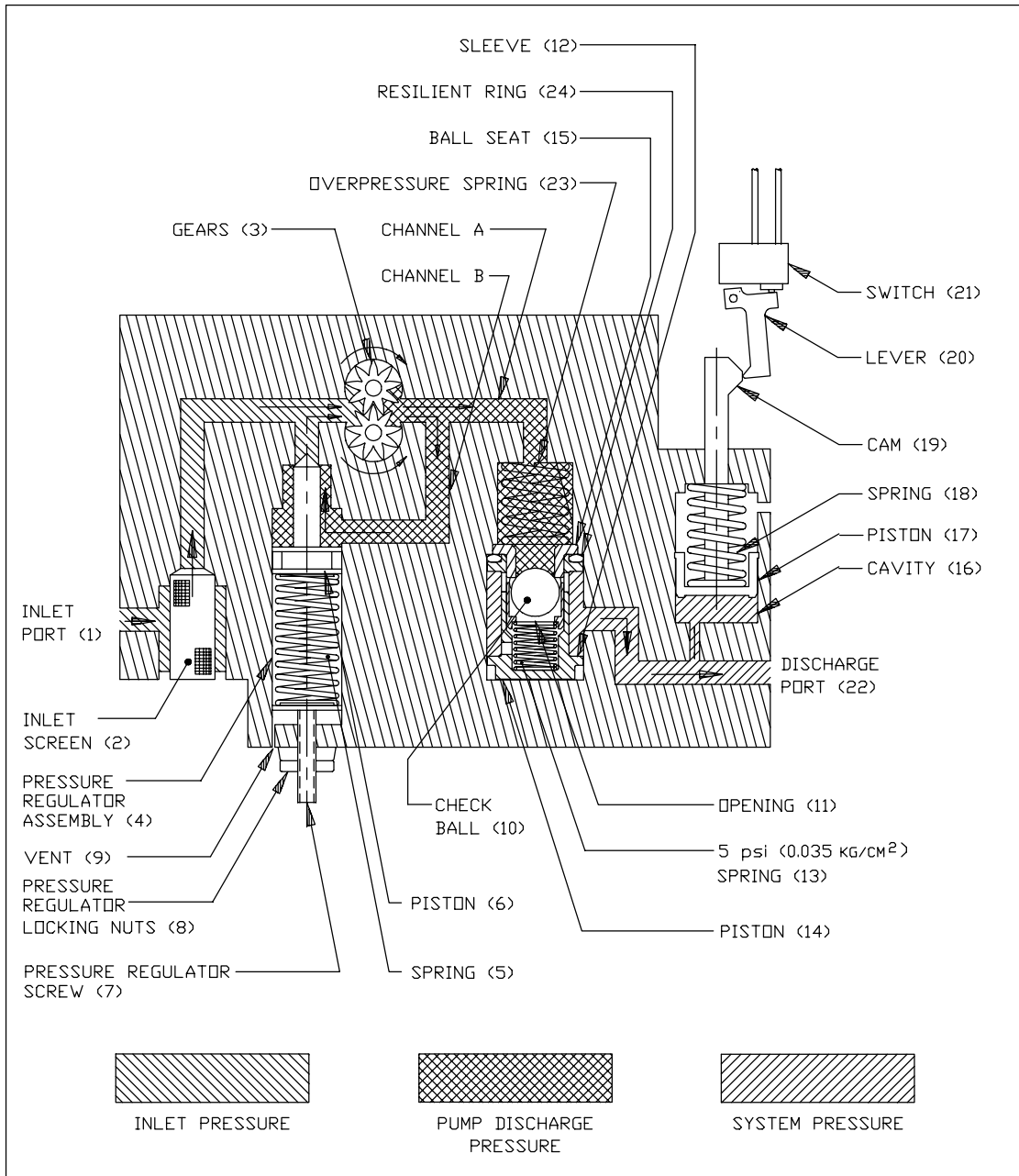

Simplified Schematic of Pump Assembly
Figure B

MICROPUMP, INC.

A Unit of IDEX Corporation

PO Box 8975, Vancouver, WA 98668-8975 • Phone: 360/253-2008 • Fax: 360/253-8294

MICROPUMP LIMITED

A Subsidiary of Micropump, Inc.

Howard Road, Eaton Socon, St. Neots, Cambridgeshire, PE 19 8ET England. • Phone: (44) (0) 1480-356600 • Fax: (44) (0) 1480-356300

- 1.3.6 When flow to the water outlets diminishes, the piston (14) is moved by spring (13) to restrict the flow past ball (10), thereby maintaining the pressure drop of approximately 5 psi as before. This condition holds, even though the flow is reduced to a trickle. However, when the flow stops completely, the fit between the end of piston (14) and the face of seat (15) is not good enough to maintain the 5 psi pressure drop at no flow. Then, with the pump still running, the pressure in the passages beyond the check ball assembly begins to rise, approaching that set by the pressure regulator (4). This increase in pressure against pressure-switch piston (17) causes the piston to rise further against spring (18), disengaging cam (19) from lever (20), allowing switch (21) to open and de-energize the motor driving the impeller (3).
- 1.3.7 As the impellers (3) come to a stop, slight backflow occurs because the impellers in their housing fit imperfectly. The backflow allows check ball (10) to seat firmly on seat (15), holding pump discharge pressure in the system and maintaining the switch (21) in the off position.
- 1.3.8 In any sealed liquid system there is always danger of an increase of pressure due to temperature changes, etc. A pressure relief must be provided. This relief is accomplished by means of spring (23) holding seat (15) in sealing contact with resilient ring (24). If a pressure rise exceeds the force of spring (23), seat (15) is free to move out of contact with the resilient ring (24). Thus, the pressure in the system is relieved by allowing a restricted flow back to the inlet port.
- 1.3.9 If system pressure approaches zero, the pressure-switch piston (17) is pushed to the bottom of its cavity by the spring (18). Cam (19) again disengages from the end of lever (20), allowing switch (21) to open and de-energize the motor-driving impellers (3). This action prevents the pump from running dry, or from running under any condition when it cannot maintain some pressure in the system to the water outlets.
- 1.3.10 An auxiliary manual starting switch (not shown) energizes the motor to establish initial water pressure in the system. Once the system pressure is established, the operation is automatic. The pump runs steadily when water is flowing to the outlets and stops only when all water outlets are closed.

2. Testing and Troubleshooting

2.1 Equipment and Materials Required

2.1.1 Equipment required for testing and troubleshooting the Model 668-28 is as follows:

2.1.1.1 One (1) each pressure gauge, 0-60 +/- 0.25 psi (0-4.14 +/- 0.02 bar).

2.1.1.2 One (1) each ohmmeter, 1X ohms range.

2.1.1.3 One (1) hand pump able to pump system pressure up to 35 psi (2.42 bar).

2.1.1.4 Two (2) each 3/8 inch (0.952 cm) cross fittings with connectors suitable for mating with pressure gauge and 3/8 inch (0.952 cm) I.D. tubing.

2.1.1.5 Two (2) each gate or globe valves with connectors suitable for mating with 3/8 inch (0.952 cm) I.D. tubing.

MICROPUMP, INC.

A Unit of IDEX Corporation

PO Box 8975, Vancouver, WA 98668-8975 • Phone: 360/253-2008 • Fax: 360/253-8294

MICROPUMP LIMITED

A Subsidiary of Micropump, Inc.

Howard Road, Eaton Socon, St. Neots, Cambridgeshire, PE 19 8ET England. • Phone: (44) (0) 1480-356600 • Fax: (44) (0) 1480-356300

- 2.1.1.6 One (1) each open-top tank with outlet connector suitable for use with 3/8 inch (0.952 cm) I.D. tubing, 1 gallon (3.81 l) minimum capacity.
- 2.1.1.7 Two (2) each AND 10050-6 to 3/8 inch (0.952 cm) adapters.
- 2.1.1.8 One (1) each 3/8 male pipe plug.
- 2.1.1.9 One (1) each circuit breaker, Heinemann SM333-1-400-1 or equivalent.
- 2.1.1.10 One (1) each switch-light assembly, Micropump 8711 or equivalent.
- 2.1.1.11 One (1) each flat blade screwdriver, 3/16 inch (0.476 cm).
- 2.1.1.12 One (1) each hex key, 0.05 inch (0.127 cm).
- 2.1.1.13 One (1) each bushing insertion tool. (Refer to Special Tools.)
- 2.1.1.14 One (1) tap, 6-32
- 2.1.1.15 One (1) each hex key, 3/32 inch (0.238 cm).
- 2.1.1.16 One (1) each dial caliper calibrated to 0.001 inch (0.00254 cm).
- 2.1.1.17 One (1) each stopwatch.

2.1.2 Materials required for testing and troubleshooting the Model 668-28 are as follows:

- 2.1.2.1 Water, amount needed to fill item (2.1.1.6) in equipment list.
- 2.1.2.2 Four (4) to five (5) feet (121.92 to 151.7 cm) of 3/8 inch (0.952 cm) I.D. Tygon tubing or equivalent.

2.2 Electrical Requirements

- 2.2.1 A 28 V dc power source capable of delivering 12 amps maximum and 5 amps continuous is needed to operate the pump motor.

2.3 Test Setup

- 2.3.1 The test setup shown in Figure C, or its equivalent, is required to check the operating condition and adjust the Model 668-28. Required electrical connections are described in Figure D.

2.4 Adjustment/Test Procedures

2.4.1 Adjustments

2.4.1.1 Over-Pressure Release Adjustment

- 2.4.1.1.1 This adjustment prevents back flow up to 30 psi system pressure.

MICROPUMP, INC.

A Unit of IDEX Corporation

PO Box 8975, Vancouver, WA 98668-8975 • Phone: 360/253-2008 • Fax: 360/253-8294

MICROPUMP LIMITED

A Subsidiary of Micropump, Inc.

Howard Road, Eaton Socon, St. Neots, Cambridgeshire, PE 19 8ET England. • Phone: (44) (0) 1480-356600 • Fax: (44) (0) 1480-356300

2.4.1.1.2 Connect Model 668-28 into test set. Close valves 1 and 2. Add one hand pump to test setup between pressure gauge and valve 2. Open valve 1 completely and valve 2 partially. Energize pump and run for one minute to establish water in test system. De-energize pump. Close valves 1 and 2. Disconnect tubing from valve 1 (pump side). Establish system pressure with hand pump, allowing pressure to build slowly to 25 psi (1.73 bar). Watch tubing disconnected from valve 1 and raise system pressure slowly toward 30 psi. Water should start to leak from tubing at 30 psi.

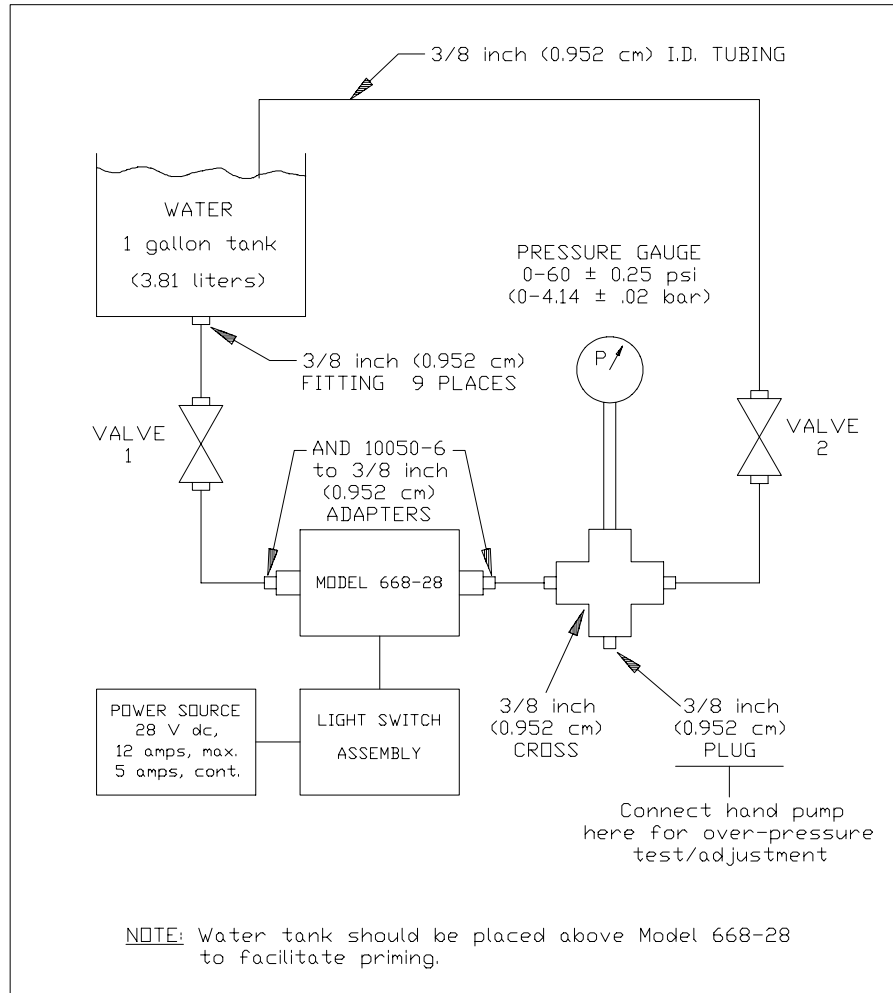

Model 668-28 Test Setup
Figure C

MICROPUMP, INC.

A Unit of IDEX Corporation

PO Box 8975, Vancouver, WA 98668-8975 • Phone: 360/253-2008 • Fax: 360/253-8294

MICROPUMP LIMITED

A Subsidiary of Micropump, Inc.

Howard Road, Eaton Socon, St. Neots, Cambridgeshire, PE 19 8ET England. • Phone: (44) (0) 1480-356600 • Fax: (44) (0) 1480-356300

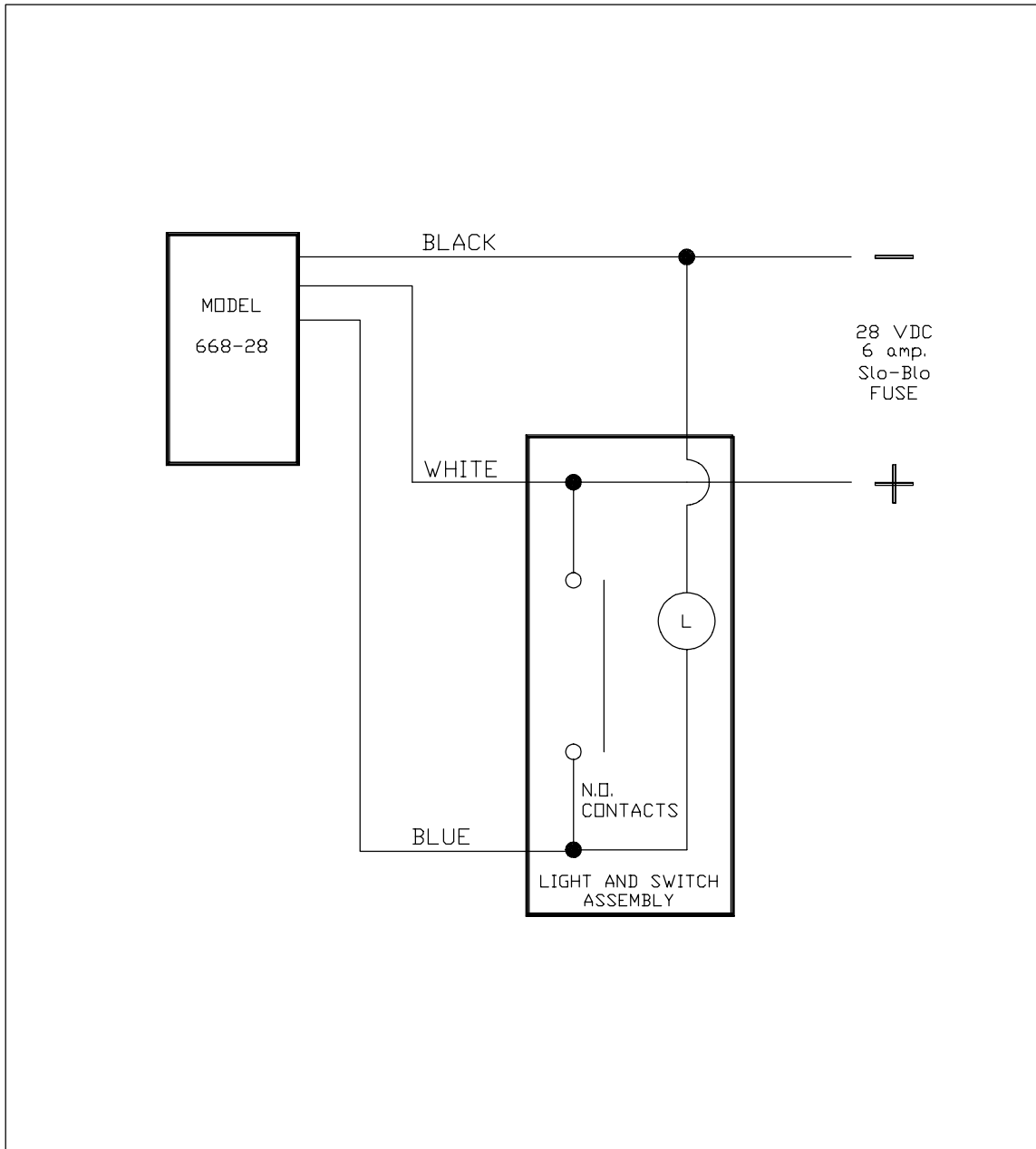

Model 668-28 and Switch-Light Assembly
 Electrical Interconnect Diagram
 Figure D

2.4.1.1.3 Adjustment involves removal or addition of shims in over-pressure release setting and requires disassembly of that setting. Refer to Disassembly and Figure 2 of

MICROPUMP, INC.

A Unit of IDEX Corporation

PO Box 8975, Vancouver, WA 98668-8975 • Phone: 360/253-2008 • Fax: 360/253-8294

MICROPUMP LIMITED

A Subsidiary of Micropump, Inc.

Howard Road, Eaton Socon, St. Neots, Cambridgeshire, PE 19 8ET England. • Phone: (44) (0) 1480-356600 • Fax: (44) (0) 1480-356300

IPL. One shim approximately equals 3 psi (.21 bar). Add shim (s) to raise setting; remove shim(s) to lower setting.

2.4.1.1.4 After adjustment, remove hand pump from test setup and reconnect tubing to valve 1.

2.4.1.2 Pressure Regulator Adjustment

2.4.1.2.1 This adjustment prevents the pump from increasing system pressure above 25 psi while in operation.

2.4.1.2.2 Connect Model 668-28 into test setup as shown in Figure C. Mount pump with pressure regulator screw in up position and motor pointing down to facilitate adjustment. Open valve 1 completely and valve 2 partially. Energize pump to establish initial system pressure. Disable pressure switch by holding down starting button during entire adjustment if necessary. Gradually close valve 2 and allow system pressure to stabilize after valve 2 is completely closed. Set pressure regulator for a 25 psi (1.73 bar) reading on pressure gauge by loosening nut and turning pressure regulator screw. Turn screw in to increase pressure and out to decrease pressure.

2.4.1.3 Pressure Switch Assembly Adjustment

2.4.1.3.1 This adjustment allows system pressure to control motor operation automatically at higher pressure, preventing pump from pumping dry at low pressure.

Note: Pump automatically shuts off at low pressure, 4 to 8 psi, and requires manually re-energizing pump.

2.4.1.3.2 It is wise to consider shims in pressure switch cavity as a rough adjustment, and setscrew on pressure switch assembly as a fine adjustment.

2.4.1.3.3 Connect Model 668-28 into test setup shown in Figure C. Mount pump with motor and pressure switch in up position. Open valve 1 completely and valve 2 partially. Energize pump to establish system pressure. Close valve 2 slowly until a 23 psi (1.59 bar) reading appears on pressure gauge. If pump shuts off before reaching a 23 psi reading, back off setscrew on pressure switch assembly using 0.050 inch (0.127 cm) hex key until pump re-starts automatically; then continue to obtain a 23 psi (1.59 bar) reading. At this reading, screw in setscrew until pump shuts off automatically. Open valve 2 slowly to decrease system pressure. Pump should restart at 22 psi. Continue decreasing system pressure. Pump should automatically shut off at 4 to 8 psi (0.28 to 0.56 bar) low pressure.

2.4.1.3.4 Adjustment involves adding shim(s) to pressure switch cavity (install below spring) and repeating process in step 2.4.1.1.3. One shim equals approximately 2 psi (.14 bar). Avoid using more than 2 shims. To add shims, remove two screws holding pressure switch assembly to cylinder. Lift pressure switch assembly from cylinder. Lift spring from cylinder. Place shim(s) in cylinder, replace spring and pressure switch assembly, and re-install screws.

2.4.1.4 Drive Magnet Assembly Adjustment

MICROPUMP, INC.

A Unit of IDEX Corporation

PO Box 8975, Vancouver, WA 98668-8975 • Phone: 360/253-2008 • Fax: 360/253-8294

MICROPUMP LIMITED

A Subsidiary of Micropump, Inc.

Howard Road, Eaton Socon, St. Neots, Cambridgeshire, PE 19 8ET England. • Phone: (44) (0) 1480-356600 • Fax: (44) (0) 1480-356300

2.4.1.4.1 The Drive Magnet Assembly must be adjusted axially so that the distance between the magnet surface and the pump end of the housing is 0.075 inch (0.1905 cm) to 0.080 inch (0.2032 cm). See Figure E.

2.4.1.4.2 To make adjustment, disassemble pump assembly from motor and drive housing assembly per Disassembly instructions. Then slowly rotate drive magnet assembly until setscrew is visible through access hole in motor housing. Loosen setscrew with a 3/32 inch (0.238 cm) hex key. Move assembly axially as required to attain specified dimension as measured with a depth gauge. Tighten setscrew. If out of radial alignment, replace assembly.

2.4.1.5 Driven Magnet Adjustment

2.4.1.5.1 Driven magnet assembly must be adjusted axially so that distance between magnet surface and back surface of base assembly is 0.130 inch (0.3302 cm) to 0.135 inch (0.3429 cm), measured with feeler gauge or dial calipers. See Figure F.

2.4.1.5.2 To take measurement, disassemble pump assembly from motor and drive housing assembly, if necessary, per Disassembly instructions. Remove screws, mounting plate and cup per pump Disassembly instructions. If adjustment is needed, apply pressure with thumb on center of magnet hub driving magnet assembly toward base assembly to decrease measurement. To increase measurement, pry up between center of magnet assembly and base assembly using two screwdrivers, one on either side. If magnet assembly is out of radial alignment, replace assembly.

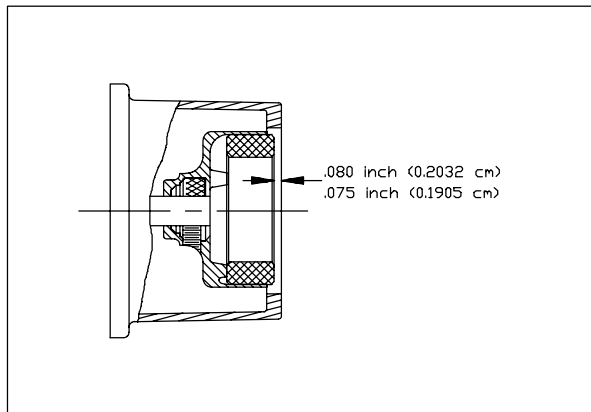

Figure E

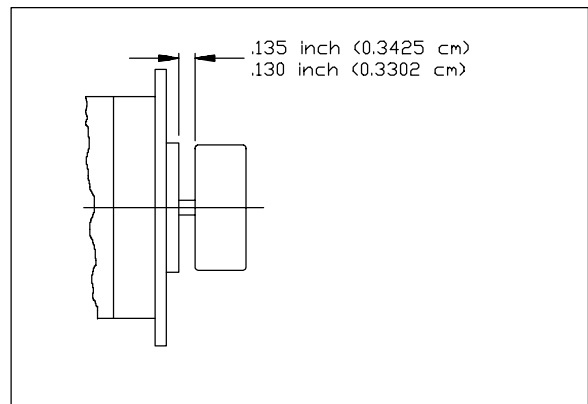

Figure F

2.4.2 Pump Test

2.4.2.1 This test is conducted using the test setup shown in Figure C. The purpose of the test is to confirm proper operation. If pump fails on any step, refer to Troubleshooting.

2.4.2.1.1 Close valves 1 and 2.

MICROPUMP, INC.

A Unit of IDEX Corporation

PO Box 8975, Vancouver, WA 98668-8975 • Phone: 360/253-2008 • Fax: 360/253-8294

MICROPUMP LIMITED

A Subsidiary of Micropump, Inc.

Howard Road, Eaton Socon, St. Neots, Cambridgeshire, PE 19 8ET England. • Phone: (44) (0) 1480-356600 • Fax: (44) (0) 1480-356300

- 2.4.2.1.2 Fill tank with water.
- 2.4.2.1.3 Connect Model 668-28 into setup as indicated.
- 2.4.2.1.4 Open valve 1 completely and valve 2 partially.
- 2.4.2.1.5 Actuate circuit breaker if required.
- 2.4.2.1.6 Energize Model 668-28 by pressing start button on switch-light assembly to establish initial system pressure. Release start button. Indicator light should remain on (motor running).
- 2.4.2.1.7 Slowly close valve 2 until indicator light shuts off (motor stops). At that moment, pressure gauge should read 22 psi (1.52 bar) to 24 psi (1.66 bar).
- 2.4.2.1.8 Re-energize Model 668-28 by holding start button down. Close valve 2 completely. Pressure should not read higher than 25 psi (1.73 bar). On releasing start button, indicator light should shut off (motor stops).
- 2.4.2.1.9 Slowly open valve 2. Pump should re-energize at 22 psi (1.52 bar) automatically. Indicator light should come on. Continue to open valve 2 until indicator light shuts off (motor stops). At that moment, pressure gauge should read 4 psi (0.28 bar) to 8 psi (0.56 bar).
- 2.4.2.1.10 Close valves 1 and 2. Add one hand pump to test setup between pressure gauge and valve 2. Open valve 1 completely and valve 2 partially. Energize pump and run for one minute to establish water in test system. De-energize pump and close valves 1 and 2. Disconnect tubing from valve 1 (pump side). Establish system pressure with hand pump, allowing pressure to build slowly to 25 psi (1.73 bar). While watching tubing disconnected from valve 1, raise system pressure slowly toward 30 psi (2.07 bar). Water should start to leak from tubing at 30 psi.
- 2.4.2.1.11 Disconnect hand pump. Open valve 1 and 2 completely. Energize pump and run for 15 seconds to establish water in test system. Disconnect tubing from valve 1 (pump side). Energize pump and run for 15 seconds to establish that the gears are wet but that the system is empty. De-energize pump and close valve 2. Reconnect tubing to valve 1. Energize pump until water reaches pump. Water should reach the pump within 30 seconds.

2.4.3 Motor Test

- 2.4.3.1 Using an ohmmeter, check that there are no short circuits between the motor leads and motor case. Then measure the resistance between the blue and black leads. The resistance should be between 1 and 3 ohms. Slowly rotate the rotor shaft and check that the resistance stays between 1 and 3 ohms. The resistance should never go to zero or infinity. If any measurement is out of specification, refer to Troubleshooting.

2.5 Troubleshooting

MICROPUMP, INC.

A Unit of IDEX Corporation

PO Box 8975, Vancouver, WA 98668-8975 • Phone: 360/253-2008 • Fax: 360/253-8294

MICROPUMP LIMITED

A Subsidiary of Micropump, Inc.

Howard Road, Eaton Socon, St. Neots, Cambridgeshire, PE 19 8ET England. • Phone: (44) (0) 1480-356600 • Fax: (44) (0) 1480-356300

2.5.1 Troubleshooting is mainly concerned with determining the nature of a trouble and making a decision to repair or replace.

2.5.2 The Troubleshooting Chart in Table 1 fully describes the routine for determining the possible cause of a malfunction. Possible causes are listed in order of ease of verification. When correction involves disassembly and replacement, refer to Disassembly and Assembly, respectively, for procedures. See Checks for procedures used to verify causes.

3. Disassembly

Note: Complete disassembly of the Pump Unit is not always required. Refer to Testing and Troubleshooting and establish Pump Unit condition or possible cause of its malfunction to determine extent of disassembly needed.

Table 1. Troubleshooting Procedure for Model for Model 668-28 Pressurematic Water System

TROUBLE	POSSIBLE CAUSES	CORRECTION
(a) Unit fails to shut off at 23 psi (1.59 bar)	(a1) Pressure switch assembly out of adjustment or bad.	Check and adjust pressure switch assembly or replace defective parts as required. Check and adjust pressure regulator.
(b) Unit fails to shut off between 4 to 8 psi (.28 to .56 bar)	(b1) Pressure switch out of adjustment or bad.	Check and adjust. Replace defective parts as required.
(c) Back flow thru pump with system pressure below 30 psi (2.07 bar)	(c1) Over-pressure release setting out of adjustment.	Check and adjust setting.
	(c2) Over-pressure release setting parts worn.	Check and replace worn parts.
(d) Unit decouples	(d1) Drive magnet mis-adjusted.	Check and adjust.
	(d2) Drive magnet rubbing on cup.	Check and adjust. Replace defective parts as required.
	(d3) Friction in impeller gears.	Check and replace as required.
	(d4) Friction in pump assembly bushings.	Check and replace as required.
	(d5) Drive magnet rubbing on cup.	Check and adjust. Replace defective parts as required.
(e) Circuit breaker trips.	(e1) Incorrect electrical Connections.	Check and correct as required.
	(e2) Insulation breakdown in motor.	Check and replace motor and drive housing with pressure switch.
(f) Motor runs Slowly.	(f1) Bad winding.	Check and replace motor and drive housing with pressure switch.
	(f2) Drive Magnet rubbing on cup.	Check and adjust. Replace defective parts as required.
(g) Incorrect winding resistance.	(g1) Short or open in winding.	Check and replace motor and drive housing with pressure switch.

MICROPUMP, INC.

A Unit of IDEX Corporation

PO Box 8975, Vancouver, WA 98668-8975 • Phone: 360/253-2008 • Fax: 360/253-8294

MICROPUMP LIMITED

A Subsidiary of Micropump, Inc.

Howard Road, Eaton Socon, St. Neots, Cambridgeshire, PE 19 8ET England. • Phone: (44) (0) 1480-356600 • Fax: (44) (0) 1480-356300

TROUBLE	POSSIBLE CAUSE	CORRECTION
(h) Pump does not prime within 30 seconds.	(h1) Water caught between pump and valve 2.	Repeat priming procedure making sure water is completely out of system.
	(h2) Bad gears.	Check and replace bad gears if defective

3.1 Disassembly of Model 668-28. (Refer to Figure 1 in IPL)

CAUTION: IF IT IS NECESSARY TO CLAMP UNIT IN A VISE TO REMOVE EXTERNAL FITTINGS, CLAMP ONLY AT FLAT SURFACE ADJACENT TO PRESSURE SWITCH.

3.1.1 Remove clamp (2) that attaches bracket (3) to Model 668-28.

3.1.2 Set clamp (2) and bracket (3) to one side.

3.2 Disassembly of Pump Assembly (5) from Motor and Drive Housing Assembly with Pressure Switch (6). (Refer to Figure 1 in IPL.)

CAUTION: IF IT IS NECESSARY TO CLAMP UNIT IN A VISE TO REMOVE EXTERNAL FITTINGS, CLAMP ONLY AT FLAT SURFACE ADJACENT TO PRESSURE SWITCH.

3.2.1 Remove six screws (4) holding pump assembly (5) to motor and drive housing with pressure switch (6).

3.2.2 Remove screws (7) holding pump assembly (5) to motor and drive housing with pressure switch (6).

3.2.3 Separate pump assembly (5) from motor and drive housing with pressure switch (6).

3.2.4 Remove spring (9), shim (10) and sleeve (11) from pump assembly.

3.3 Disassembly of Pump Assembly (-1). (Refer to Figure 2 in IPL.)

Note: Place all parts on clean surface.

3.3.1 Remove screws (3) holding plate (4) to base assembly (7).

3.3.2 Remove plate (4) and cup (5).

3.3.3 Remove magnet assembly (6) by prying up between base assembly (7) and magnet assembly.

3.3.4 Remove base assembly (7).

3.3.5 Remove O-rings (8) and (9) from both sides of base assembly (7).

3.3.6 Remove gear assemblies (11) and (12).

MICROPUMP, INC.

A Unit of IDEX Corporation

PO Box 8975, Vancouver, WA 98668-8975 • Phone: 360/253-2008 • Fax: 360/253-8294

MICROPUMP LIMITED

A Subsidiary of Micropump, Inc.

Howard Road, Eaton Socon, St. Neots, Cambridgeshire, PE 19 8ET England. • Phone: (44) (0) 1480-356600 • Fax: (44) (0) 1480-356300

3.3.7 Remove bushings (10) from base assembly (7).

3.3.8 Remove bushings (13) from body assembly (2).

3.3.9 Remove screws (14) holding adjuster assembly (15) to body assembly (2) and remove adjuster assembly.

CAUTION: DO NOT TAMPER WITH ADJUSTER SCREW (16) AND NUT (17); THEY ARE PRE-SET.

3.3.10 Remove retainer (18), spring (19), retainer (20), O-ring (21), and piston (22).

CAUTION: KEEP THESE PARTS TOGETHER AND INSURE THAT SPRINGS ARE KEPT WITH MATING PARTS.

3.3.11 Remove adapter (23), spring (24), sleeve (25), ball (26), plate (27), shim (28), and spring (29). Remove O-rings (30) and (31) from both ends of adapter (23). Keep all parts together.

3.3.12 Remove cap (32) from body assembly (2). Remove screen (33) and remove O-ring (34) from cap.

3.3.13 Remove screws (35) attaching cylinder (36) to body assembly (2). Remove cylinder (36), O-ring (37), and piston (38).

3.4 Disassembly of Motor and Drive Housing Assembly with Pressure Switch (-1). (Refer to Figure 3 in IPL.)

Note: Do not damage or shorten external wiring if motor is to be re-used.

3.4.1 Rotate drive magnet (3) to align setscrew (2) with access hole in drive housing (4).

3.4.2 Loosen setscrew (2) with 3/32 inch (0.238 cm) hex key. Pull drive magnet (3) straight off rotor shaft.

4. Cleaning

4.1 Cleaning Agents and Materials

Note: Equivalent substitutes may be used for listed items.

4.1.1 Stoddard solvent.

4.1.2 Masking tape.

4.2 Cleaning Procedures

4.2.1 General

4.2.1.1 Clean all metal and plastic parts in Stoddard solvent. Blow dry with clean, dry compressed air.

CAUTION: DO NOT USE SOLVENT ON ELECTRICAL PARTS OR MOTOR BEARINGS.

4.2.2 Pump Housing

MICROPUMP, INC.

A Unit of IDEX Corporation

PO Box 8975, Vancouver, WA 98668-8975 • Phone: 360/253-2008 • Fax: 360/253-8294

MICROPUMP LIMITED

A Subsidiary of Micropump, Inc.

Howard Road, Eaton Socon, St. Neots, Cambridgeshire, PE 19 8ET England. • Phone: (44) (0) 1480-356600 • Fax: (44) (0) 1480-356300

- 4.2.2.1 Remove any foreign matter or residue from pump housing and blow dry with clean, dry compressed air.

CAUTION: DO NOT SCRATCH INTERIOR SURFACES OF ANY HOLES IN BODY ASSEMBLY.

4.2.3 Magnet Assembly and Drive Magnet

- 4.2.3.1 Remove any particles from magnets by pressing sticky side of masking tape against particles and removing tape.

5. Checks

5.1 Condition of Pump Assembly

- 5.1.1 Visually check outside of cup for rub marks on back and side. Back marks indicate drive magnet is misadjusted axially. Refer to Testing and Troubleshooting. Side marks indicate that drive magnet is radially misaligned, possibly due to a bent rotor shaft. Refer to Repair.
- 5.1.2 Visually check inside surfaces of cup for rub marks. Marks on back indicate a loose magnet assembly fit on gear shaft. Side marks indicate worn bushings or radial misalignment. Refer to Testing and Troubleshooting and Repair.
- 5.1.3 Check O-ring grooves on both side of base assembly for foreign material that might cause O-ring to seat improperly.
- 5.1.4 Visually check gears for wear. Check that shafts are not deeply grooved and that gear teeth have not changed shape as compared with a new gear. Slight grooving of shafts is normal if grooves look polished.
- 5.1.5 Check gear movement for backlash and smooth meshing. Look for tight centers or any tendency to stick.
- 5.1.6 Inspect bushings in body assembly and base assembly. Using a No. 30 drill blank, check that interior surfaces are not excessively worn out of round. Drill blank should pass all the way through but not be loose.

Note: Gear shafts normally fit loosely in bushings. Excessively loose bushings, however, can cause wear and should be replaced. Refer to Repair.

- 5.1.7 Inspect cavity in body assembly and wear surface on base assembly for excessive wear or imperfections. Some circular grooving is normal and not undesirable.
- 5.1.8 Check inlet screen for foreign material that could restrict flow.
- 5.1.9 Check ball in flow sensor/system check/over-pressure release valve assembly for resiliency.
- 5.1.10 Inspect orifice in pressure switch assembly section of body for foreign material that might be clogging the hole.
- 5.1.11 Check all O-rings (seven in all) in pump assembly for cracks and wear.

MICROPUMP, INC.

A Unit of IDEX Corporation

PO Box 8975, Vancouver, WA 98668-8975 • Phone: 360/253-2008 • Fax: 360/253-8294

MICROPUMP LIMITED

A Subsidiary of Micropump, Inc.

Howard Road, Eaton Socon, St. Neots, Cambridgeshire, PE 19 8ET England. • Phone: (44) (0) 1480-356600 • Fax: (44) (0) 1480-356300

5.2 Condition of Motor and Drive Housing Assembly with Pressure Switch

5.2.1 Drive Magnet Assembly Condition

5.2.1.1 Visually check drive magnet assembly for chips, cracks or other damage. Also check for magnetic grit accumulation. Refer to Repair and Cleaning.

Note: It is not necessary to disassemble motor for following checks.

5.2.2 Rotor and Bearing Condition

5.2.2.1 Check that rotor turns freely. If bearings appear tight, see Repair.

5.2.2.2 Check rotor shaft for setscrew marks other than on flat. If such marks are found, check for bent rotor shaft. Refer to Repair.

5.2.3 Motor Condition

5.2.3.1 Perform motor test given in Testing and Troubleshooting. If motor does not pass test, refer to Repair.

6. Repair

6.1 Tools and Materials

6.1.1 The following tools and materials may be required to effect repairs:

6.1.1.1 One (1) each 6-32 tap.

6.1.1.2 One (1) each bushing insertion tool. Refer to Special Tools.)

6.1.1.3 Service Kit, P/N 81732.

6.2 Pump Assembly

6.2.1 Repair of pump assembly is limited to replacing parts.

6.2.1.1 Replacement of O-rings is recommended each time pump is disassembled. (Included in P/N 81732 Service Kit.)

Note: Actual replacement may be based on in-service experience.

6.2.1.2 Replace any parts that show physical damage such as cracks, breaks and scarring.

6.2.1.3 Replace body and/or pump assembly if interior or lip of any hole is damaged.

6.2.1.4 Replace inlet screen if it is corroded.

6.2.1.5 Replace ball in flow sensor/system check/over-pressure valve assembly if it is hard.

MICROPUMP, INC.

A Unit of IDEX Corporation

PO Box 8975, Vancouver, WA 98668-8975 • Phone: 360/253-2008 • Fax: 360/253-8294

MICROPUMP LIMITED

A Subsidiary of Micropump, Inc.

Howard Road, Eaton Socon, St. Neots, Cambridgeshire, PE 19 8ET England. • Phone: (44) (0) 1480-356600 • Fax: (44) (0) 1480-356300

6.2.2 Bushing replacement (Refer to Figure 2 in IPL.)

6.2.2.1 To remove bushing, run 6-32 tap into bushing three or four turns and pull bushing out.

6.2.2.2 Insert bushing into hole in body or pump base assembly and seat with bushing insertion tool. Seat bushing to 0.15 inch (0.038 cm) below body or pump base surface as applicable.

6.3 Motor and Drive Housing Assembly with Pressure Switch

6.3.1 Repair of the motor and drive housing assembly with pressure switch is limited to replacing the entire assembly, including the pressure switch. Replacement should be made for any motor that does not pass the motor test (refer to Testing and Troubleshooting). Also replace if rotor shaft is bent.

7. Assembly

7.1 The following tools and materials are required to assemble the Model 668-28.

Note: Equivalent substitutes may be used.

7.1.1 One (1) each 3/32 inch (0.238 cm) hex key.

7.1.2 One (1) each flat blade screwdriver, 3/16 inch (0.476 cm).

7.1.3 Dow Corning high-vacuum grease.

7.2 Assembly of Pump Assembly (-1). (Refer to Figure 2 in IPL.)

CAUTION: DO ALL WORK ON CLEAN SURFACE.

7.2.1 Install screen (33) in body assembly (2). Lightly lubricate O-ring (34) with specified grease and place into groove in cap (32). Thread cap into body assembly.

7.2.2 Insert piston (22) in pressure regulator hole in body assembly (2). Lightly lubricate O-ring (21) with specified grease and place on lip inside pressure regulator hole. Install retainer (20), spring (19), and retainer (18).

7.2.3 Install spring (29), shim or shims (28), plate (27), ball (26), and sleeve (25) in remaining hole in body assembly (2). Then add spring (24), adapter (23) with O-ring (30) and (31) at each end of adapter.

7.2.4 Place adjuster assembly (15) with adjusting screw (16) and nut (17) over assemblies installed in Steps 7.2.2 and 7.2.3. Attach to body assembly (2) with two screws (14).

7.2.5 Place drive gear (11) in center hole in body assembly (2). Insert driven gear (12) in other hole in body assembly. Spin gear (11) to check mesh and free rotation.

7.2.6 Lightly lubricate O-rings (8) and (9) with specified grease. Install on each side of base assembly (7) with odd-shaped O-ring groove on pump side of base. Mate base assembly (7) to body assembly (2).

MICROPUMP, INC.

A Unit of IDEX Corporation

PO Box 8975, Vancouver, WA 98668-8975 • Phone: 360/253-2008 • Fax: 360/253-8294

MICROPUMP LIMITED

A Subsidiary of Micropump, Inc.

Howard Road, Eaton Socon, St. Neots, Cambridgeshire, PE 19 8ET England. • Phone: (44) (0) 1480-356600 • Fax: (44) (0) 1480-356300

- 7.2.7 Press driven magnet assembly (6) onto protruding slotted shaft of drive gear (11) with raised side of magnet assembly on motor side of assembly. Press to dimension shown in Adjustments (See Figure F).
- 7.2.8 Install cup (5) and plate (4) so that raised lugs on plate face away from pump assembly. Install four screws (3) and tighten.
- 7.2.9 Lightly grease O-ring (37) with specified grease and place on lip inside pressure switch hole in body assembly (2). Install piston (38) in pressure switch hole. Attach cylinder (36) to body assembly (2) with four screws (35).

7.3 Assembly of Motor and Drive Housing Assembly with Pressure Switch (-1). Refer to Figure 3 in IPL.)

CAUTION: DO ALL WORK ON A CLEAN SURFACE.

- 7.3.1 Thread setscrew (2) part way into drive magnet (3).
- 7.3.2 Rotate rotor shaft to align flat portion of shaft with access hole in drive housing (4).
- 7.3.3 Install drive magnet (3) on rotor shaft so that setscrew (2) aligns with flat portion of shaft.
- 7.3.4 Set drive magnet (3) to axial dimension specified in Testing and Troubleshooting and tighten setscrew (2) with 3/32 inch (0.238 cm) hex key.

7.4 Assembly of Pump Assembly (5) and Motor and Drive Housing with Pressure Switch (6). (Refer to Figures 1 and 2 in IPL.)

- 7.4.1 Mate pump assembly (5) to motor and drive housing assembly with pressure switch (6).
- 7.4.2 Install six screws (4) and tighten.
- 7.4.3 Insert sleeve (11) into cylinder (36), followed by shim (10) and spring (9).
- 7.4.4 Install screws (7) and tighten.
- 7.4.5 Submit Model 668-28 to pump test. See Testing and Troubleshooting.

7.5 Assembly of Model 668-28. (Refer to Figure 1 in IPL.)

- 7.5.1 Install bracket (3) on Model 668-28.
- 7.5.2 Attach bracket (3) to Model 668-28 with clamp (2).

7.6 Storage

7.6.1 Preparation

- 7.6.1.1 Install plugs in outlet and inlet ports.

Note: Tape can be used in lieu of plugs to cap ports.

MICROPUMP, INC.

A Unit of IDEX Corporation

PO Box 8975, Vancouver, WA 98668-8975 • Phone: 360/253-2008 • Fax: 360/253-8294

MICROPUMP LIMITED

A Subsidiary of Micropump, Inc.

Howard Road, Eaton Socon, St. Neots, Cambridgeshire, PE 19 8ET England. • Phone: (44) (0) 1480-356600 • Fax: (44) (0) 1480-356300

7.6.2 Storage Conditions

7.6.2.1 Store Model 668-28 in horizontal position in a normal ambient temperature-humidity environment.

9. Special Tools

9.1 Only one special tool, a bushing insertion tool, is required to maintain the Model 668-28 Pressurematic Water System. It is used to press new bushings into the pump body assembly and base assembly. The bushing insertion tool is fully described in Figure G. It is available from Micropump Corp. as P/N 5465.

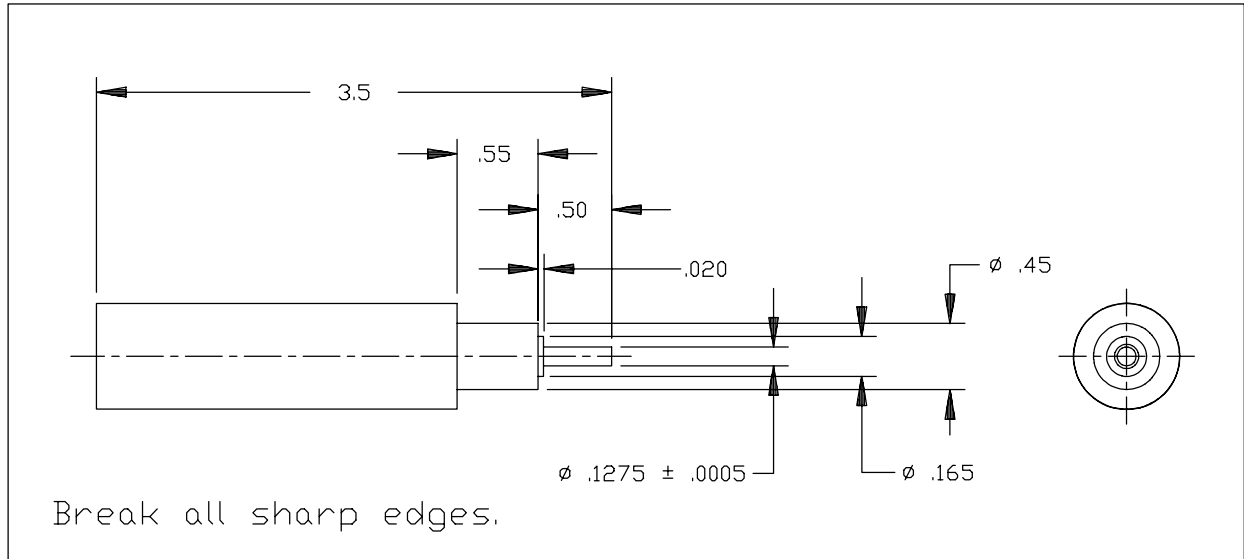

Bushing Insertion Tool
Figure G

10. Illustrated Parts List (IPL)

10.1 Introduction

10.1.1 Purpose

10.1.1.1 The IPL provides all the information required to order replacement or spare parts for the Model 668-28 Pressurematic Water System. All procurable parts are fully described and illustrated.

10.1.2 Availability

10.1.2.1 Parts are available from the manufacturer of the Model 668-28.
MICROPUMP, INC.

10.1.3 How To Use the IPL

MICROPUMP, INC.

A Unit of IDEX Corporation

PO Box 8975, Vancouver, WA 98668-8975 • Phone: 360/253-2008 • Fax: 360/253-8294

MICROPUMP LIMITED

A Subsidiary of Micropump, Inc.

Howard Road, Eaton Socon, St. Neots, Cambridgeshire, PE 19 8ET England. • Phone: (44) (0) 1480-356600 • Fax: (44) (0) 1480-356300

10.1.3.1 Refer to the illustration in the Detailed Parts List that pertains to the assembly in which the part is used. Find the part in the illustration and note the item number. Then refer to the parts list that accompanies the illustration for the part number, nomenclature, and quantity used per assembly.

10.2 Detail Parts List

10.2.1 The Detailed Parts List consists of illustrations and columnar parts breakdown of the Model 668-28 Pressurematic Water System, its assemblies, and parts that can be disassembled, repaired, replaced, and reassembled.

10.2.1.1 Figure 1 with its parts breakdown details the Model 668-28 Pressurematic Water System.

10.2.1.2 Figure 2 with its parts breakdown details the pump assembly.

10.2.1.3 Figure 3 with its parts breakdown details the motor and drive housing assembly with pressure switch.

MICROPUMP, INC.

A Unit of IDEX Corporation

PO Box 8975, Vancouver, WA 98668-8975 • Phone: 360/253-2008 • Fax: 360/253-8294

MICROPUMP LIMITED

A Subsidiary of Micropump, Inc.

Howard Road, Eaton Socon, St. Neots, Cambridgeshire, PE 19 8ET England. • Phone: (44) (0) 1480-356600 • Fax: (44) (0) 1480-356300

FIGURE ITEM	PART NO.	AIRLINE PART NO.	NOMENCLATURE	UNITS PER ASSY.
1-1	8940		Model 668-28 Pressurematic Water System (MICROPUMP MOD* 19-35-401-8940)	1
			ATTACHING PARTS	
2	3358		* Clamp	1
3	2508		* Bracket	1
4	2772		* Screw	6
5	81731		Pump Assembly	1
6	8942		Motor and Drive Housing Assembly	1
			ATTACHING PART	
7	1437		* Screw	2
8*	8711		Switch-Light Assembly	1
9	2644		Spring, Pressure Switch	1
10	2794		Shim, Pressure Switch	A/R
11	2793		Sleeve, Pressure Switch	1

A/R = As required

* See Electrical interconnection diagram, Figure D (Page 10).

MICROPUMP, INC.

A Unit of IDEX Corporation

PO Box 8975, Vancouver, WA 98668-8975 • Phone: 360/253-2008 • Fax: 360/253-8294

MICROPUMP LIMITED

A Subsidiary of Micropump, Inc.

Howard Road, Eaton Socon, St. Neots, Cambridgeshire, PE 19 8ET England. • Phone: (44) (0) 1480-356600 • Fax: (44) (0) 1480-356300

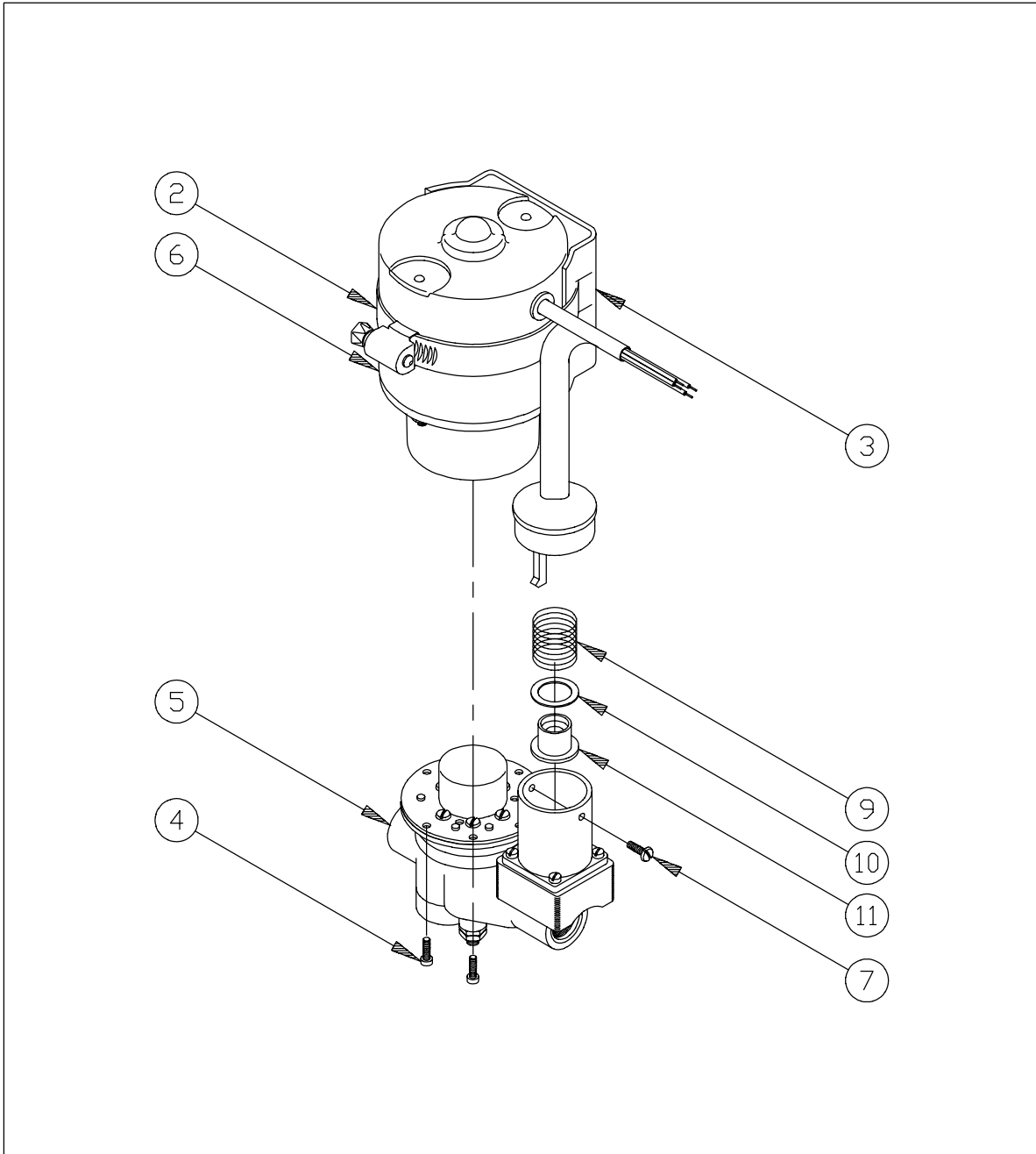

Model 668-28 Pressurematic Water System
Figure 1

MICROPUMP, INC.

A Unit of IDEX Corporation

PO Box 8975, Vancouver, WA 98668-8975 • Phone: 360/253-2008 • Fax: 360/253-8294

MICROPUMP LIMITED

A Subsidiary of Micropump, Inc.

Howard Road, Eaton Socon, St. Neots, Cambridgeshire, PE 19 8ET England. • Phone: (44) (0) 1480-356600 • Fax: (44) (0) 1480-356300

FIGURE ITEM	PART NO.	AIRLINE PART NO.	NOMENCLATURE	UNITS PER ASSY.
2-1	81731		Pump Assembly	1
2	8517		Body Assembly, Pump	1
			ATTACHING PART	
3	1725		Screw	4
4	2301		Plate, Pump Mounting	1
5	3279		Cup	1
6	8946		Magnet Assembly	1
7	8519		Base Assembly	1
8	808		O-Ring	1
9	3051		O-Ring	1
10	4913		Bushing	2
11	81729		Gear, Driving	1
12	81730		Gear, Driven	1
13	4913		Bushing	2
			ATTACHING PART	
14	795		Screw	2
15	8526		Adjuster Assembly	1
16	2576		Screw, Adjuster	1
17	2784		Nut	1
Continued on next page.				

MICROPUMP, INC.

A Unit of IDEX Corporation

PO Box 8975, Vancouver, WA 98668-8975 • Phone: 360/253-2008 • Fax: 360/253-8294

MICROPUMP LIMITED

A Subsidiary of Micropump, Inc.

Howard Road, Eaton Socon, St. Neots, Cambridgeshire, PE 19 8ET England. • Phone: (44) (0) 1480-356600 • Fax: (44) (0) 1480-356300

FIGURE ITEM	PART NO.	AIRLINE PART NO.	NOMENCLATURE	UNITS PER ASSY.
18	2785		Retainer, Adjuster Spring	1
19	2643		Spring, Adjuster	1
20	2785		Retainer	1
21	1541		O-Ring	1
2-22	4141		Piston	1
23	2364		Adapter	1
24	7920		Spring	1
25	2786		Sleeve	1
26	1395		Ball	1
27	2577		Plate	1
28	3311		Shim	A/R
29	2578		Spring	1
30	1541		O-Ring	1
31	1541		O-Ring	1
32	3360		Cap	1
33	1900		Screen, Inlet	1
34	903		O-Ring	1
			ATTACHING PART	
35	799		Screw	4
36	3723		Cylinder	1
37	1374		O-Ring	1
38	2789		Piston	1

A/R = As Required

MICROPUMP, INC.

A Unit of IDEX Corporation

PO Box 8975, Vancouver, WA 98668-8975 • Phone: 360/253-2008 • Fax: 360/253-8294

MICROPUMP LIMITED

A Subsidiary of Micropump, Inc.

Howard Road, Eaton Socon, St. Neots, Cambridgeshire, PE 19 8ET England. • Phone: (44) (0) 1480-356600 • Fax: (44) (0) 1480-356300

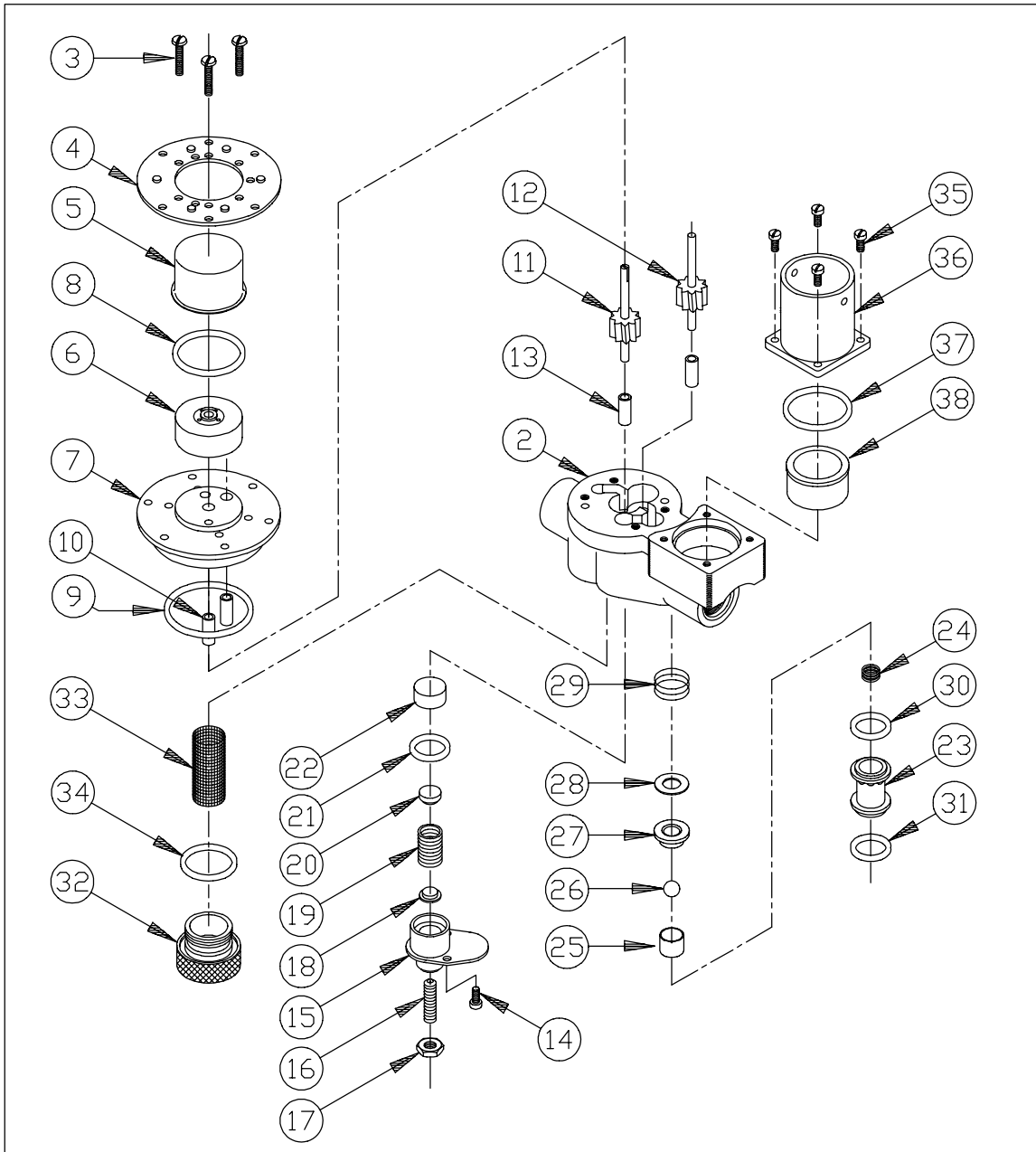

Model 668-28 Pump Assembly
Figure 2

MICROPUMP, INC.

A Unit of IDEX Corporation

PO Box 8975, Vancouver, WA 98668-8975 • Phone: 360/253-2008 • Fax: 360/253-8294

MICROPUMP LIMITED

A Subsidiary of Micropump, Inc.

Howard Road, Eaton Socon, St. Neots, Cambridgeshire, PE 19 8ET England. • Phone: (44) (0) 1480-356600 • Fax: (44) (0) 1480-356300

FIGURE ITEM	PART NO.	AIRLINE PART NO.	NOMENCLATURE	UNITS PER ASSEMBLY
3-1	8942		Motor and Drive Housing with Pressure Switch	1
			ATTACHING PART	
2	814		Set Screw	1
3	9719		Hub Assembly - Drive Magnet	1
4	2121		Motor	1

MICROPUMP, INC.

A Unit of IDEX Corporation

PO Box 8975, Vancouver, WA 98668-8975 • Phone: 360/253-2008 • Fax: 360/253-8294

MICROPUMP LIMITED

A Subsidiary of Micropump, Inc.

Howard Road, Eaton Socon, St. Neots, Cambridgeshire, PE 19 8ET England. • Phone: (44) (0) 1480-356600 • Fax: (44) (0) 1480-356300

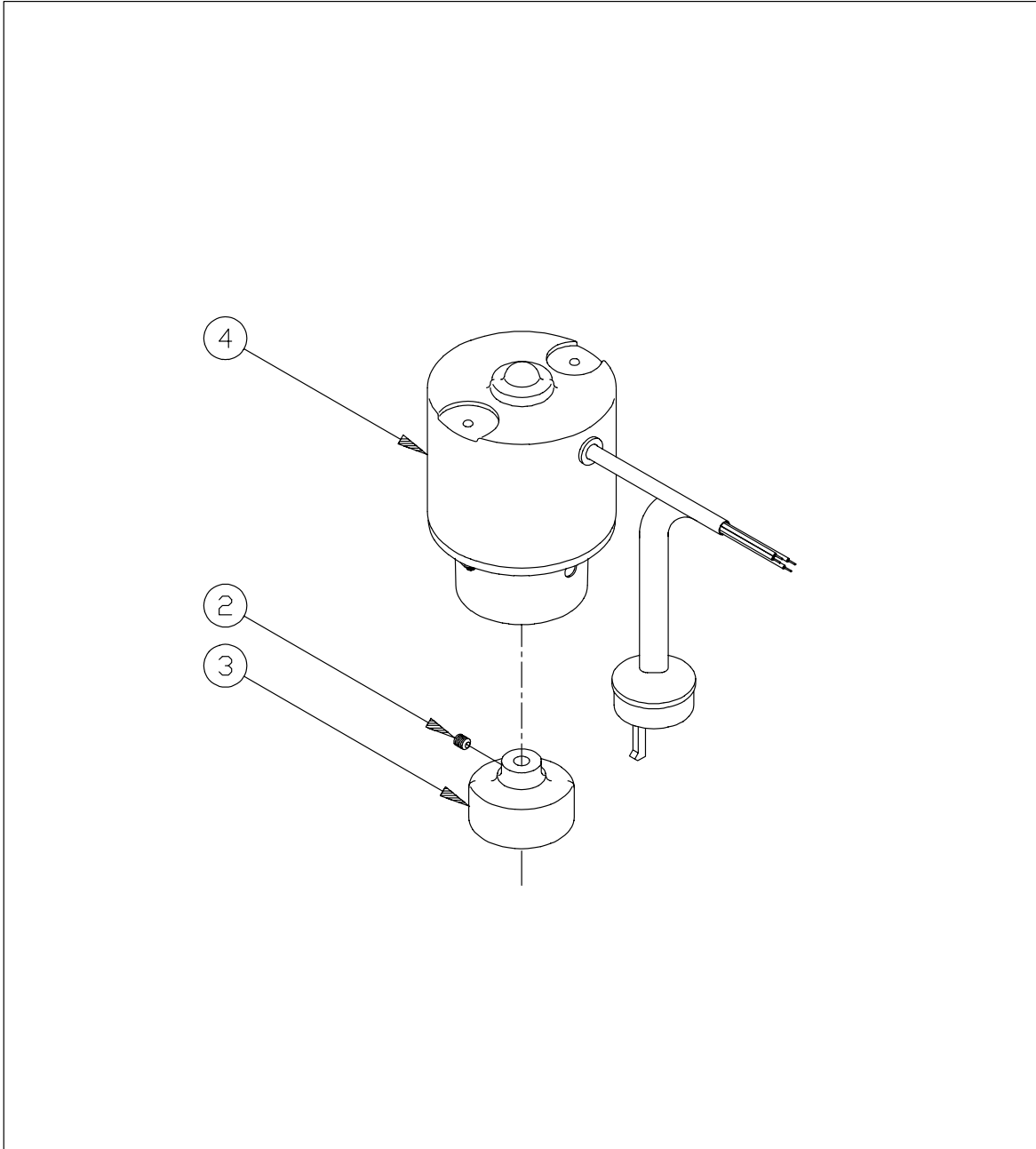

Model 668-28 Motor and Drive Housing with Pressure Switch
Figure 3

MICROPUMP, INC.

A Unit of IDEX Corporation

PO Box 8975, Vancouver, WA 98668-8975 • Phone: 360/253-2008 • Fax: 360/253-8294

MICROPUMP LIMITED

A Subsidiary of Micropump, Inc.

Howard Road, Eaton Socon, St. Neots, Cambridgeshire, PE 19 8ET England. • Phone: (44) (0) 1480-356600 • Fax: (44) (0) 1480-356300